



CHEFTOP *MIND Maps™* PLUS





CHEFTOP MIND.Maps™ PLUS

Designed to fulfill your ambitions.

Controllable like your hand. Natural as your thoughts. Intelligent and connected.
This is CHEFTOP MIND.Maps™ PLUS by UNOX, the professional oven that breaks down every barrier between your ideas and their achievement. With one gesture.

 Watch the “Touch of Brilliance” video on the official UNOX YouTube channel

Your success will speak volumes.



CHEFTOP MIND.Maps™ PLUS

The solution you need in whatever size you want.

The CHEFTOP MIND.Maps™ PLUS ovens are the culmination of UNOX's years of research and experience of working alongside the most demanding chefs as they take on the daily challenge of making their creative ideas a reality. They are designed to be easy to use and to guarantee top performance in all working conditions. They use the latest smart technologies to give real support in your work and to adapt to any kitchen, whatever the size.

The 6 and 10 tray full size models and the 5 and 10 tray hotel pan models are the benchmark for every kitchen and, thanks to the possibility of creating stacked oven columns to meet your specific needs, they are perfect for every food service situation.

The freestanding 16 tray full size roll-in trolley models are reliable workhorses that are perfectly suited to large scale banqueting and production kitchens.

The compact 5 tray hotel pan models are the solution for kitchens where space is a key concern and where performance cannot be compromised. Perfect results, every time.

 Watch the "Touch of Brilliance" video on the official UNOX YouTube channel

Unox Intelligent Performance

Intelligent Cooking. Guaranteed results.

Achieving identical results for each load requires control, intelligence and expertise. Every detail counts: what happens before and during cooking, the various load quantities, food whose properties vary with the seasons and the unique manual techniques of each member of your team. For example?

Cooking multiple trays requires more time than for just one or two: the door remains open for longer and the consequent drop in temperature is greater. The oven must begin cooking at a lower temperature and cook a higher quantity of food, for which more time is required to achieve the correct working conditions.

In addition, the humidity emitted by the fully-loaded oven is greater than a partial load, and if the door is opened unexpectedly, it significantly alters all the parameters of the cooking process.

Achieving repeatable results requires continual supervision, monitoring of every detail and immediate intervention. In a few words: control, intelligence and expertise.

Exactly what a CHEFTOP MIND.Maps™ PLUS oven with UNOX INTELLIGENT. Performance provides.



ADAPTIVE.Cooking™ Perfect results. Every time.

The ADAPTIVE.Cooking™ technology transforms your oven into an intelligent tool capable of interpreting your settings and understanding your desired result. Through its sensors and intelligence, your CHEFTOP MIND.Maps™ PLUS registers changes in humidity and temperature. It effectively understands the quantity of food inserted into the oven to then automatically regulate the cooking process by acting on all the parameters and modulating the combined action of the INTENSIVE.Cooking™ technologies, guaranteeing you an identical and perfect result every time. Exactly as you imagined.

CLIMALUX™ Total humidity control.

The actual humidity present inside the cooking chamber is the total of that produced by the oven and that generated by the evaporation of the water present in the food. Through CLIMALUX™ intelligent technology, your CHEFTOP MIND.Maps™ PLUS uses precise sensors to measure the effective humidity inside the oven and acts automatically when steam is emitted or humidity is extracted to ensure that the cooking conditions match the chosen settings. This is how CLIMALUX™ simultaneously guarantees repeatable cooking processes and water and energy savings even exceeding 90% when compared to traditional combination ovens.

AUTO.Soft Gentle cooking function.

A sharp increase in temperature in the presence of delicate products and in high oven load capacity conditions can compromise the uniformity of the overall result.

When the AUTO.Soft function is activated, your CHEFTOP MIND.Maps™ PLUS oven automatically regulates the rise in temperature according to what the sensors detect to make it gentler and guarantee an optimal distribution of heat inside each pan in the oven. Because every detail counts when your requirements take pride of place.

SMART.Preheating Intelligent preheating.

Correctly preheating the oven creates the ideal conditions to optimise cooking from the very first moments once the door is closed.

Your UNOX CHEFTOP MIND.Maps™ PLUS is equipped with new SMART.Preheating intelligent technology that automatically sets the best temperature and preheating time according to the parameters of the chosen cooking process and to what has occurred in previous hours. As always, to guarantee you maximum repeatability of results at all times of the day and energy savings up to 20% compared to manual preheating.

SENSE.Klean Intelligent cleaning.

Your CHEFTOP MIND.Maps™ PLUS oven is an intelligent piece of machinery equipped with technology that offers you maximum levels of cooking performance. Correct cleaning is essential to ensure that the sensors and components function correctly over time, therefore maintaining high levels of cooking performance day after day, month after month, year after year. SENSE.Klean™ technology estimates the degree of dirt and suggests the best automatic cleaning mode according to actual use. To guarantee you maximum hygiene and avoid unnecessary waste of water and detergent.

Unox Intelligent Performance

Maximum performance. Guaranteed in all conditions.

Intelligent technologies designed to maximize your work, improve performance, and help you achieve your ambitions of building success. Every single day.
Find out how UNOX INTELLIGENT.Performance technologies influence the cooking process, correct common mistakes and exponentially improve daily results.
Perfection will become the norm.



OPTIMAL SETTINGS FOR A HALF LOAD

SALMON

PRE 500°C

6 mins

465°F

0%

WITHOUT ADAPTIVE. COOKING™

The quantity of food in the oven has an effect on the final result: a program set for a single tray will not be sufficient to cook a full load and, viceversa, a program set for a full load will overbake a single tray load.

WITH ADAPTIVE. COOKING™

ADAPTIVE.Cooking™ technology recognises the quantity of food in the cooking chamber and automatically optimises the time, temperature and climatic conditions.

RESULTS WITH A SINGLE TRAY

WITHOUT ADAPTIVE. COOKING™

Cooking time:
6 minutes
Actual average temperature:
480 °F
Actual average level of humidity during the cooking program: **0%**

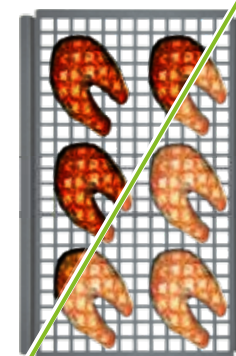

WITH ADAPTIVE. COOKING™

Cooking time:
6 minutes
Actual average temperature:
465 °F
Actual average level of humidity during the cooking program: **0%**



RESULTS WITH A FULL LOAD

WITHOUT ADAPTIVE. COOKING™

Cooking time:
5 minutes
Actual average temperature:
430 °F
Actual average level of humidity during the cooking program: **50%**

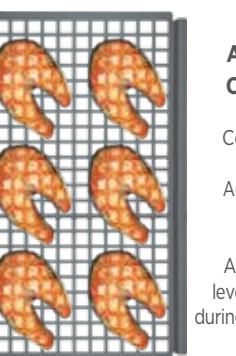
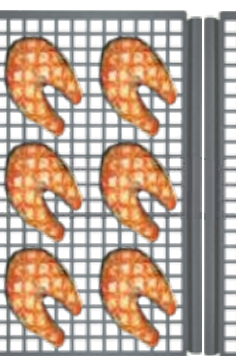
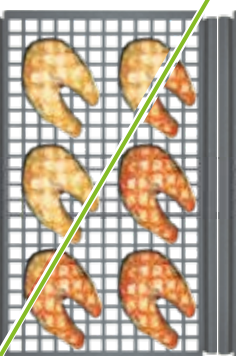
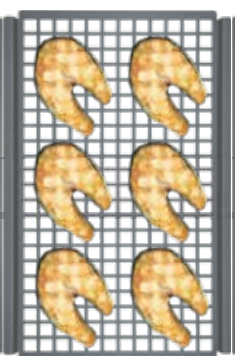
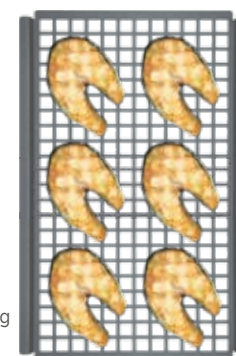

WITH ADAPTIVE. COOKING™

Cooking time:
8 minutes
Actual average temperature:
465° F
Actual average level of humidity during the cooking program: **0%**



WITHOUT CLIMALUX™
Combination cooking

The uncontrolled presence of humidity in the cooking chamber will affect the cooking results, with a negative impact on the external color and internal structure that changes with the amount of foodload

WITH CLIMALUX™
Combination cooking

CLIMALUX™ registers variations in humidity and reacts rapidly to extract any excess humidity and therefore guarantees the required humidity conditions with any food-load.

OPTIMAL SETTINGS FOR A HALF LOAD

ROAST CHICKENS

PRE 410 °F

38 mins

375 °F

30%

RESULTS WITH A SINGLE TRAY

WITHOUT CLIMALUX™

Actual average level of humidity during the cooking program: **20%**

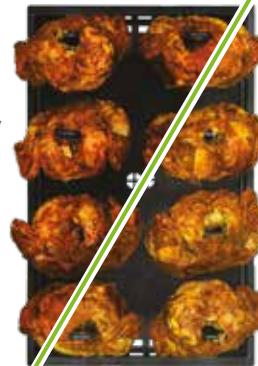

WITH CLIMALUX™

Actual average level of humidity during the cooking program: **30%**

RESULTS WITH A FULL LOAD

WITHOUT CLIMALUX™

Actual average level of humidity during the cooking program: **80%**

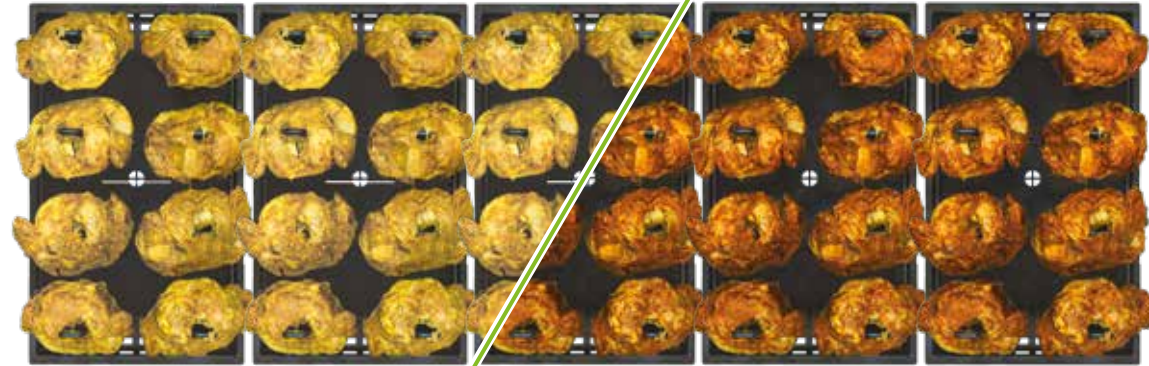

WITH CLIMALUX™

Actual average level of humidity during the cooking program: **30%**

WITHOUT CLIMALUX™
Steaming

Steaming is the combi oven cooking method that uses the most amount of energy and water. Without the ability to detect steam saturation, the oven continues to produce steam and use energy even when it is not necessary.

WITH CLIMALUX™
Steaming

CLIMALUX™ continuously measures the actual percentage of humidity in the cooking chamber and detects when full saturation is reached, reducing thereafter the steam production to the exact quantity needed to maintain saturation.

STEAMED POTATOES

PRE 230 °F

20 mins

212 °F

100%

WITHOUT CLIMALUX™

Actual average level of humidity during the cooking program: **100%**

Average consumption:
kW: 3,15
Gal of H2O: 2,58

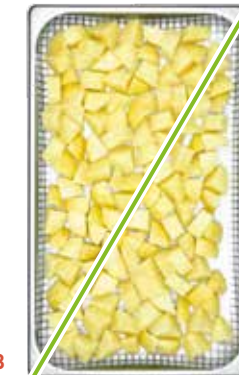

WITH CLIMALUX™

Actual average level of humidity during the cooking program: **100%**

Average consumption:
kW: 1,66
Gal of H2O: 4,1

WITHOUT CLIMALUX™

Actual average level of humidity during the cooking program: **100%**

Average consumption:
kW: 9,00
Gal of H2O: 1,08

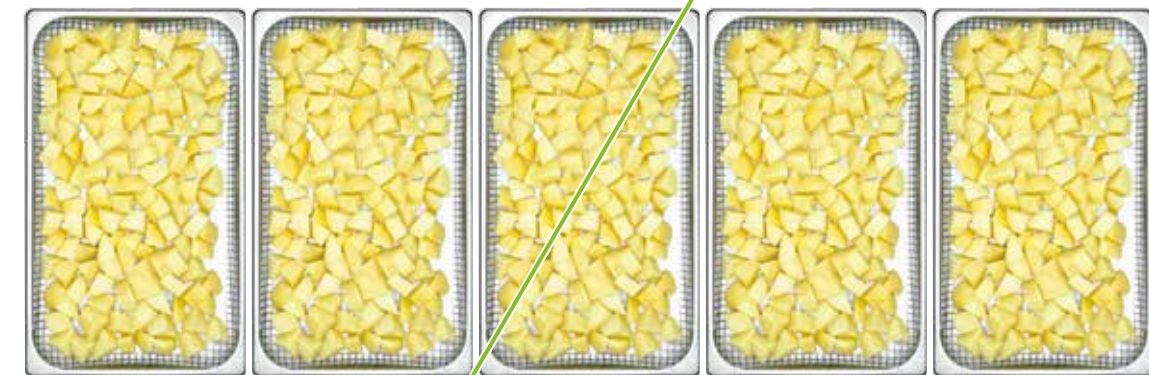

WITH CLIMALUX™

Actual average level of humidity during the cooking program: **100%**

Average consumption*:
kW: 7,51
Gal of H2O: 1,43

* Certified according to ENERGY STAR: Steam Mode Cooking Energy Efficiency: cooking at 212 °F 100% humidity

WITHOUT AUTO.SOFT

The change from one cooking step to the next a rapid increase in temperature can be so aggressive that delicate products are cooked unevenly.

WITH AUTO.SOFT

The AUTO.Soft function manages the rise in temperature, making it more delicate and maintaining uniformity on all points of the tray and on all the trays.

POTATOES STEP 1/2

10 mins

212 °F

100%

STEP 2/2

20 mins

375 °F

100%

WITHOUT AUTO.SOFT

Rise time: 212 °F - 375 °F: **1 minute**



WITH AUTO.SOFT

Rise time: 212 °F - 375 °F: **7 minutes**

WITHOUT AUTO.SOFT

Rise time: 212 °F - 375 °F: **3 minutes**



WITH AUTO.SOFT

Rise time: 212 °F - 375 °F: **7 minutes**

WITHOUT SMART.PREHEATING

The oven preheats to the set temperature without taking into account if and how the oven has been used before, with the risk of not being hot enough for the first cooking program of the day, or on the other hand wasting energy during the preheating phase when the cooking chamber has already accumulated sufficient heat during previous cooking programs.

WITH SMART.PREHEATING

SMART.Preheating recognizes the activity that the oven has carried out before the cooking starts and intelligently adjusts the preheating accordingly: making it more intense with the first cook in the morning when the oven is cold, and reducing it or even skipping it should the oven chamber already be hot enough to start cooking right away. This leads to always perfect cooking results while saving time and energy.

BREAD

PRE 410 °F

18 mins

355 °F



WITHOUT SMART.PREHEATING

Preheating time: **6 minutes**
Temperature of the oven chamber steel after preheating: **212 °F**

Preheating time: **6 minutes**
Temperature of the oven chamber steel after preheating: **375 °C**



WITH SMART.PREHEATING

Preheating time: **9 minutes**
Temperature of the oven chamber steel after preheating: **355 °F**

Preheating time: **0 minutes**
Temperature of the oven chamber steel after preheating: **355 °F**

WITHOUT SMART.PREHEATING

Preheating time: **6 minutes**
Temperature of the oven chamber steel after preheating: **212 °F**

Preheating time: **6 minutes**
Temperature of the oven chamber steel after preheating: **375 °F**

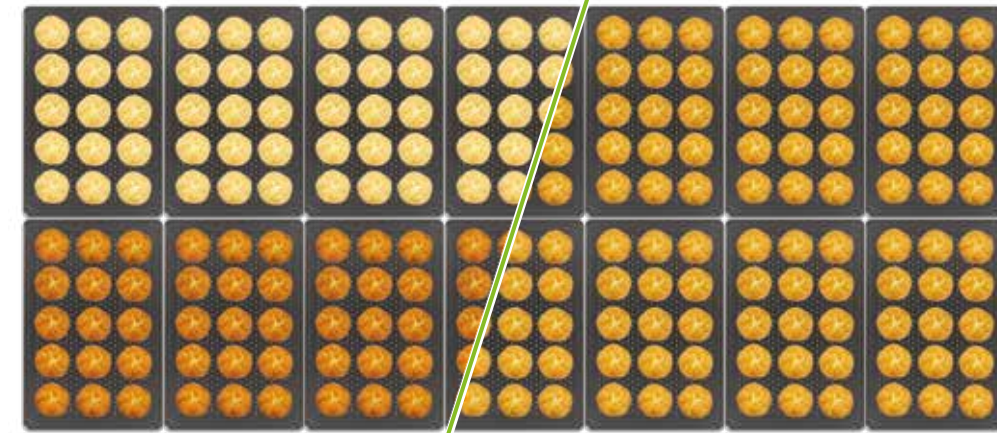

WITH SMART.PREHEATING

Preheating time: **9 minutes**
Temperature of the oven chamber steel after preheating: **355 °F**

Preheating time: **0 minutes**
Temperature of the oven chamber steel after preheating: **355 °F**

DDC - Data Driven Cooking

Your oven is unique, intelligent and connected.

The Data Driven Cooking artificial intelligence technology is designed to help you make the most of the potential of your UNOX CHEFTOP MIND.Maps™ PLUS oven: it collects data, processes information, analyzes the modes of use and gives you a daily report, and connects to the Internet cloud to identify and suggest recipes and personalized hints for your actual needs, which translate directly into new products for your clients. With Data Driven Cooking, UNOX CHEFTOP MIND.Maps™ PLUS ovens become much more than a simple piece of kitchen equipment.

They become a true partner that contributes to the creation of your success.

Data Driven Cooking.
Closer to you, closer to your success.

Innovation Award



▶ Watch the "Data Driven Cooking" video



DDC.Ai - Artificial Intelligence Your personalised virtual assistant.

When connected to the UNOX Cloud online, your CHEFTOP MIND.Maps™ PLUS oven sends data to activate the DDC.Ai service, which uses artificial intelligence to process it in order to identify and suggest recipes and personalized hints for your actual needs, which you can immediately transform into new dishes for your menu. The results speak for themselves: after three months of activating the DDC.Ai service, the average use of the oven increases by 25%, and with that, so does the profitability of your investment.

DDC.Unox and DDC.App Everything just a click away.

With the ddc.unox.com Internet portal and DDC.UNOX App, you have control of your connected CHEFTOP MIND.Maps™ PLUS oven even when you are not in the kitchen.

You can monitor its operating status in real time, collect and analyze usage and HACCP data from previous months, create recipes from your computer, receive those that DDC.Ai suggests and send them to your ovens with a simple click.

DDC.Stats Monitored for constant improvement.

Your CHEFTOP MIND.Maps™ PLUS oven monitors and analyzes energy, water and detergent consumption, registers cooking times and counts the minutes the door is open; the DDC.Stats function translates them into valuable, useful and clear information that is directly viewable on the control panel to genuinely help you identify every opportunity for improvement and eliminate any waste, hence increasing your daily profit.

Unox Intensive Cooking

You chose not to settle for less. Maximum cooking intensity.

Thanks to its technology, your CHEFTOP MIND.Maps™ PLUS oven is the most efficient and evolved cooking instrument in your kitchen, capable of guaranteeing extremely high performance levels and noticeable savings in terms of time, energy and labor in each one of its applications.

Perfect cooking, uniformity in each pan inserted into the oven, saturated and dense steam in a few seconds or complete extraction of humidity, intense or gentle air flows. The combination oven taken to its maximum expression.

But that's not all: UNOX INTENSIVE.Cooking also allows you to use your CHEFTOP MIND.Maps™ PLUS for cooking that is normally carried out with traditional equipment such as static or convection ovens.

The savings? It's substantial: up to 45% less energy compared to a traditional grill, over 60% less water compared to cooking in boiling water, up to 80% less oil compared to a fryer. And above all an assistant who continually monitors the cooking process without further labor costs.



DRY.Maxi™

Humidity gives way to flavour.

Humidity is extracted, removed, eliminated. In part or completely, you decide. Give your preparations perfect consistency, color and crunchiness every time. Well defined and subtle flavors, never mixed together. Meat, fish and vegetables maintain their identity and enhance their characteristics even when cooked at the same time. DRY.Maxi™ is the technology you'll never go without; the absence of humidity gives your more flavorful preparations even greater concentration. Ending a cooking process with DRY.Maxi™ will be like signing your masterpiece. Get used to doing great things.

STEAM.Maxi™

The power of steam is in your hands.

The continuous and rigorous control and precise calculation of the humidity changes in the cooking chamber make STEAM.Maxi™ your best ally in your cooking processes. From a hot dense cloud that envelops your food, to partial humidity. From 95 to 500 °F degrees.

Everything you want. As you want it. STEAM.Maxi™ adapts to high cooking performance and at the same time guarantees energy and water savings thanks to the on-demand production of steam that is regulated by precise algorithms. Perfection. Density and Intensity.

AIR.Maxi™

Conducts, unites, transforms.

The high-flow multi-fan AIR.Maxi™ system offers reliable results in every application. Powerful air flows capable of pushing heat into the depth of food, shortening cooking times for meat, fish and vegetables, grilled, fried or roast food, but which also provide controlled and gentle ventilation for gentle cooking, dehydration, delicate browning and overnight cooking. AIR.Maxi™ technology guarantees the best uniformity of cooking in every load condition for every kind of food thanks to the rotation reversals that occur according to the load and food type. Choose not to settle for less.

EFFICIENT.Power™

Power and efficiency.

High-efficiency heating elements or Spido.GAS™ forced air burners system with patented symmetrical heat exchangers: whichever power source you choose for your CHEFTOP MIND.Maps™ PLUS, you're always guaranteed maximum performance and efficiency. Maximum speed of temperature rise and precisely maintaining it, energy savings ensured by the triple-glazed door and high performance insulating materials. In figures? From 140 to 500 °F in 300 seconds in both electric and gas models. Category leading efficiency in combi mode, dry air and steam according to ENERGY STAR certification.

PLUS control panel

The pleasure of being in full control

Innovative yet simple - its the new frontier of communication between you and your oven.

The control panel of your CHEFTOP MIND.Maps™ PLUS is the result of combining revolutionary ideas with ease of use.

With its 9.5 inch touch screen, the CHEFTOP MIND.Maps™ PLUS control panel gives you maximum possibility of choice: create your own program, use one of the many automatic cooking programs available and manage up to 10 timers simultaneously. The choice is yours. CHEFTOP MIND.Maps™ PLUS will always be ready.

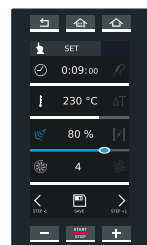

SET
Simple.
Comprehensive.
Intuitive.

The freedom to create any cooking program, in a clear and intuitive way. All of your parameters appear on one screen. You can set hours, minutes and seconds, or choose infinity cooking mode or even an overnight program.

Choose the temperature you want, choose the climatic conditions and the fan speed. Create up to 9 steps in your cooking program, to cook anything that you want, exactly as you want it.

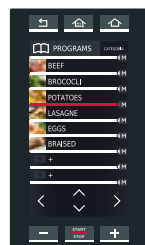

PROGRAMS
Your masterpieces.
Today, tomorrow,
forever.

All of your creations are unique and repeatable thanks to your personal recipe book which allows you to save and organise your cooking programs. CHEFTOP MIND.Maps™ PLUS allows you to save over 380 programs and to organize them into 16 different groups, so you can group your recipes according to who will use them or according to type of food, such as meat, fish, vegetables and deserts. It will become an invaluable tool in your kitchen.

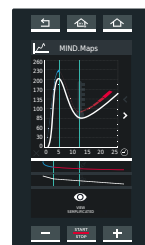

MIND.Maps™
Don't select a
cooking program,
draw your own.

Add your Touch of Brilliance. Freely, whenever you want. Make your creativity repeatable. The MIND.Maps™ visual language technology allows the most elaborate cooking processes to be created by hand on the control panel. With the pen set in the handle of your CHEFTOP MIND.Maps™ PLUS you can draw even the most complex cooking processes with the utmost creative freedom and then repeat them whenever you want. You create, the oven works.



CHEFUNOX
Choose what you
want to cook.
Start. That's it.

Imagine you have full use of a library of cooking programs calibrated to achieve the best results with zero waste of time and raw material. Choose the cooking method, select the food category, set the degree of cooking required and your CHEFTOP MIND.Maps™ PLUS oven will do the rest. CHEF.UNOX is the answer to the demand for high and repeatable quality standards. In every situation.

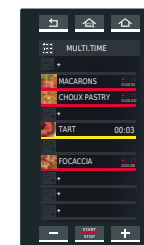

MULTI.Time
Multitasking
you've always
dreamed of.

The frenzy of service at peak times, shouting out orders, pressure, heat, tension. The need to manage everything in the shortest time possible. Orderly and organized. This is the moment in which MULTI.Time technology comes into play, giving you the possibility of managing up to 10 cooking processes at the same time and always having maximum control at a glance.



MISE.EN.PLACE
We've gone further
than kitchen
organisation.

The incredible possible. With MISE.EN.PLACE, your CHEFTOP MIND.Maps™ PLUS oven acquires even more value and intelligence.

Thanks to a unique and intuitive function, it recommends the correct order and times to insert each pan into the cooking chamber so that all your products are ready at the same time. Being on time has never been so simple.

Every detail counts. And you know it.

Designed and built for perfection.



TRIPLE GLASS - ENERGY STAR CERTIFIED



MULTI-POINT CORE PROBE

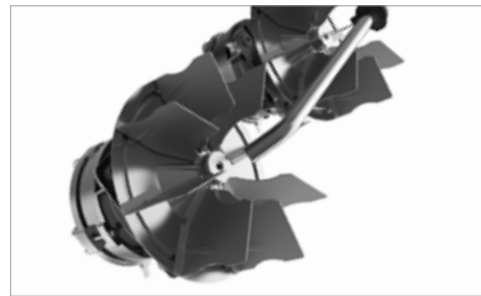

4 SPEED MULTIPLE FAN SYSTEM



HIGH PERFORMANCE INSULATION MATERIAL



STAINLESS STEEL AISI 304 COOKING CHAMBER



9.5" LCD TOUCH SCREEN CONTROL PANEL



LED CHAMBER ILLUMINATION INTEGRATED IN THE DOOR



ETHERNET/WIFI CONNECTION CONFIGURATION



EXTRA FINE SOUS VIDE CORE PROBE - OPTIONAL



DOOR DOCKING POSITIONS AT 60°/120°/180°



ANTI TIP TRAY SUPPORTS



CARBON FIBRE DOOR HANDLE



USB PORT FOR UPLOAD/DOWNLOAD OF DATA



FORCED AIR BURNERS WITH SYMMETRICAL HEAT EXCHANGERS



ANTI CONDENSATE DRIP TRAY



Rotor.KLEAN™ AUTOMATIC WASHING

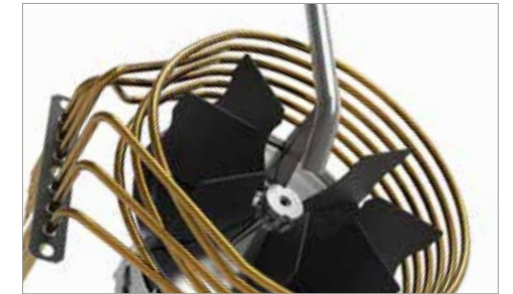

HIGH PERFORMANCE HEATING ELEMENTS



SMART CLOSURE FOR TROLLEY OVENS



INTEGRATED DET&RINSE TANK



PERFORATED LATERAL SUPPORTS

The products manufactured by UNOX are protected by one or more of the following patents or patent applications: IT 139373; US 8.071.917; DE 10160225.8; ES 2369245; DE 10201010245.0; IT 1398088; US 8.712.561; DE 102011010753.3; IT 1398091; DE 102011014669.5; IT 1399068; US9188521; IT 272303; DE 102011014141.3; IT 1398861; US 8662066; IT 1402074; DE 602006001437; ES 2308664; IT 502008901655862; DE 102007060439.6; ES 2340454; IT 1412358; IT 1427160; IT 1425779; DE 102015114648; US 14845950; DE 102015114648; IT 1428030; IT 283033; IT 283033; ES 1157660; IT 202015000008735; IT 202015000006785; US 15050960; DE 202016100941; IT 202015000008010; IT 2020150000010018; IT 102015000015162; DE 102016108769; IT 102015000020928; IT 102016000034750; DE 10201707164; US 15471624; IT 202015000063980; US 15297709; DE 202016105830; IT 202016000069424; IT 202017000052355; IT 202015000031518; IT 102015000041480; IT 202017000052318; IT 1378934; in addition to other pending patents.

Find out more. Watch the video "MIND.MAPS™. DESIGNED FOR YOUR SUCCESS" on the official UNOX YouTube channel



Fresh kitchen air.

Certified ventless hood.

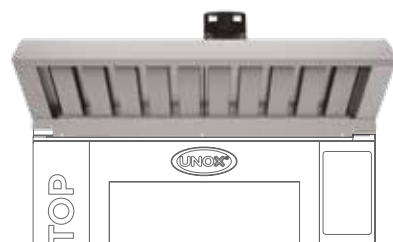

The UNOX steam condensing hood is an ideal solution for installing your CHEFTOP MIND.Maps™ PLUS oven in any point of your kitchen.

Within the hood a self-cleaning filter removes odors and latent heat from the fumes that are expelled through the oven chimney, without the need for maintenance or cleaning work on the filter.

Choosing a UNOX ventless hood is an investment that will save you money.

It allows you to install your CHEFTOP MIND.Maps™ PLUS even without* a ceiling canopy, or to prefilter the fumes and reduce maintenance on the centralized extraction system.

*subject to inspection and approval by organisations and to local regulations.



HYPER.SMOKER

Smoke. Cook. Amaze.



OPTIONAL ACCESSORIES

**Enrich your dishes,
amaze your guests.
HYPER.Smoker, your
small secret.**

HYPER.Smoker by UNOX transforms your CHEFTOP MIND.Maps™ PLUS into a smoker. You can use shavings of natural wood and choose from among 10 different smoking intensities directly from the control panel of the oven to amaze even the most demanding of palates, giving smoked undertones to your dishes.

Choosing HYPER.Smoker for your CHEFTOP MIND.Maps™ PLUS will allow you to smoke food by using the energy produced in the cooking chamber without further costs and external electrical power supply.

The easiest process for the maximum flavour.



Solutions for production kitchens and banqueting.
Quality, quantity and speed are of the essence.

QUICK.Load & QUICK.Plate

Productivity and efficiency are the key to the success of production kitchens, banqueting rooms, hotels, large schools and large restaurants. Every second counts, every opening of the door is important. The oven has to continue its work without ever being interrupted.

The QUICK.Load rack system for CHEFTOP MIND.Maps™ allows you to cook large quantities of dishes in a very short time with minimal heat loss and the shortest time between one cooking process and the next.

For large banquets the QUICK.Plate racks allow you to regenerate up to 51 dishes in a few minutes, avoiding the formation of condensation thanks to the CLIMALUX continuous humidity control of your CHEFTOP MIND.Maps™ PLUS oven. The HOLDING.Cover thermal cover allows you to keep them warm before serving.



QUICK.Load
16 trays full size 18"x26"

CHEFTOP MIND.Maps™ PLUS
16 trays full size 18"x26"

QUICK.Plate
51 plates



A good start is half of the work.

**Knead,
and it'll do the rest.**

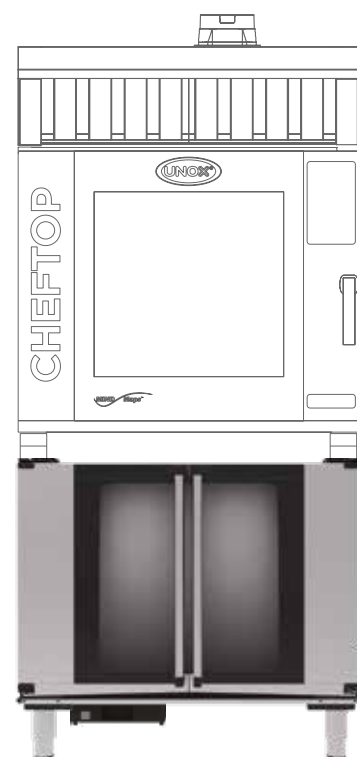

Proving is a balancing act between dough, temperature, humidity temperature and time, and is one of the crucial moments that determines the quality of the final product. The CHEFTOP MIND.Maps™ PLUS proofers are equipped with precise sensors that accurately and continuously control the temperature and humidity at each point of the proving process and intervene to always guarantee excellent and repeatable results.

The CHEFTOP MIND.Maps™ PLUS proofers are available in the 12 pan versions for column installations.





**SMART.Drain.
Cooking fat and liquid
collection system**

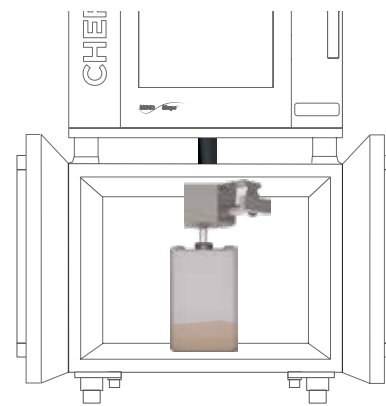

Several cooking processes that are typically carried out in supermarkets, production kitchens and steak houses such as grilling, frying and roasting full loads of pork, poultry and beef can create a large amount of fat. In this case it becomes very important to protect your drainage from the threat of possible blockage.

UNOX have developed SMART.Drain as a solution to this problem. SMART.Drain is a special two-way valve that collects any fat and cooking liquids created during the cooking program and drains them into a tank. For each one of your cooking programs, you can set the correct position of the valve directly on the control panel, which will be automatically monitored by your CHEFTOP MIND.Maps™ PLUS before the start of the cooking to avoid any risk of the drain being blocked by solidified collagen and grease released by the food during the cooking program, which could in turn cause serious damage to the kitchen/shop.



OPEN SOLUTION

CHEFTOP MIND.Maps™ PLUS
+ SMART.Drain
+ High open stand



CLOSED SOLUTION

CHEFTOP MIND.Maps™ PLUS
+ SMART.Drain
+ Closed neutral cabinet

**+
THE COMPLETE
PACKAGE**



Ventless hood



Pollo tray

MAXI.LINK

Not only time, but space is also money.

With MAXI.Link™ you can create stacked oven and accessory columns in order to make the most of the vertical space and keep the footprint to a minimum. The advantages are clear in terms of flexibility and energy efficiency: you can carry out different cooking processes at the same time and only use the necessary ovens, avoiding waste. Two smaller ovens instead of one larger one, with the same total tray capacity, will allow a notable reduction in service time and therefore an increase in profits.

Not only time, but space is also money. MAXI.Link™ allows you to save space, as it optimises every centimetre in your kitchen.



PRACTICALITY
Restaurant 40/60 covers



5 TRAYS 12"x20" COMPACT
5 TRAYS 12"x20" COMPACT

PROFITABILITY
Restaurant 60/100 covers



6 TRAYS 18"x26"
6 TRAYS 18"x26"

VERSATILITY
Restaurant 100/200 covers



10 TRAYS 12"x20"
NEUTRAL CABINET

FLEXIBILITY
Butcher & Deli Shop



10 TRAYS 18"x26"
NEUTRAL CABINET

PRODUCTIVITY
Hotel & Banqueting



5 TRAYS 18"x26"
5 TRAYS 18"x26"

RELIABILITY
Marine



6 TRAYS 18"x26" - 600x400 - GN 2/1
6 TRAYS 18"x26" - 600x400 - GN 2/1



COOKING & BAKING ESSENTIALS

Special trays.

The collection of UNOX Cooking & Baking Essentials special trays transforms your CHEFTOP MIND.Maps™ PLUS from an oven to a multifunctional cooking centre.

Each cooking operation requires a tray with precise characteristics to spread the heat in a specific way.

The special Cooking Essentials in fact enable you to steam, grill, fry, brown and roast, using the full potential of your CHEFTOP MIND.Maps™ PLUS and impressing your guests.

BACON

Removable steel grid with a non-stick steel tray h40 to collect grease.



IDEAL FOR:

- Bacon
- Sausage
- Roast meat
- Spatchcock chicken

ADVANTAGES

- Grill up to 18 slices of crispy bacon in 5 minutes
- Easy to clean thanks to the non-stick coating

EGGX

Non-stick steel tray for frying eggs.



IDEAL FOR:

- Fried eggs
- Omelettes
- Pancakes
- Tortillas

ADVANTAGES

- Fry up to 12 eggs in less than 4 minutes
- Light, hard-wearing and easy to clean

STEAM&FRY

Stainless steel grid for steaming or regenerating pre-fried foods.



IDEAL FOR:

- Chips
- Pre-fried items
- Sous vide cooking
- Steamed vegetables

ADVANTAGES

- Battered vegetables ready in just 4 minutes
- Duel use: steaming and cooking pre-fried items

FORO.BLACK

Non-stick perforated aluminium pan.



IDEAL FOR:

- Croissants
- Fresh bread
- Danish pastries
- Pastry

ADVANTAGES

- Baking parchment is not required
- Ultra low edge for maximum baking uniformity

FORO.BAKE

Perforated aluminium pan.



IDEAL FOR:

- Pastry
- Cakes
- Baking on silicon mats

ADVANTAGES

- Perforated surface to allow better transpiration of moisture
- Ultra low edge for maximum baking uniformity

CHROMO.GRID

Chromed grid.



IDEAL FOR:

- Pastry products in baking tin
- Dry baking

ADVANTAGES

- Possibility to hang dry baking products on the tray
- Ultra-resistant chromed steel

FORO.BAGUETTE

Perforated aluminium tray with 5 channels to bake baguettes.



IDEAL FOR:

- Frozen baguettes

ADVANTAGES

- Bake up to 10 mini baguettes in 20 minutes
- Perforated for maximum air flow

POLLO.BLACK

Non-stick tray with supports to roast full chickens and collect grease



IDEAL FOR:

- Roast chickens
- Steamed chickens

ADVANTAGES

- Vertical supports optimize air flow around each chicken for perfect results
- Fat is collected and drained towards the centre to avoid excess dirt in the chamber

BLACK.20

Non-stick stainless steel pan h 20mm



IDEAL FOR:

- Ratatouille
- Roast potatoes
- Roast fish

ADVANTAGES

- Roasting without any waste
- Easy to clean

GRILL

Non-stick aluminium tray for grilling. Preheating of the tray is not required.

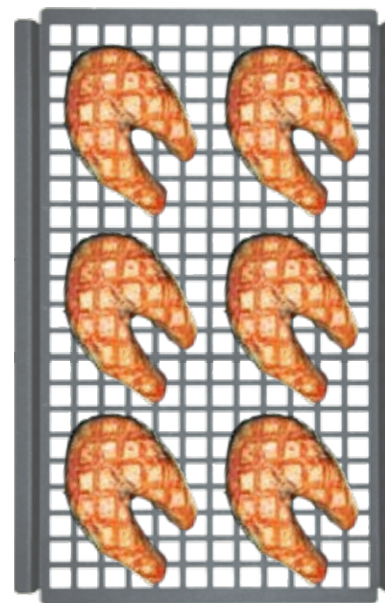

IDEAL FOR:

- Grilled fish
- Grilled vegetables
- Grilled meat

ADVANTAGES

- Grill up to 18 filets of fish in 6 minutes
- Useful for batch grilling as preheating is not required

PAN.FRY

Enamel coated pan for frying breaded products.



IDEAL FOR:

- Croquettes
- Breaded fish filets
- Breaded cutlets
- Breaded vegetables

ADVANTAGES

- Reduces the amount of cooking grease and oil
- Uniform cooking on every point of the tray



UNOX.CARE PROGRAM

Protect the performance you deserve.

DET&Rinse™ is the detergent and rinse aid especially designed to ensure every day maximum hygiene levels, lower consumption rates and the durability of every component of your CHEFTOP MIND.Maps™ PLUS oven with SENSE.Klean intelligent automatic washing. You can choose between double concentration DET&Rinse™ PLUS for harder to shift dirt or DET&Rinse™ ECO for daily cleaning and maximum eco friendliness. Every bottle of DET&Rinse™ has a hermetic safety seal which prevents the release of liquid until it has been correctly screwed into the built-in drawer of your CHEFTOP MIND.Maps™ PLUS oven to ensure maximum peace of mind during loading operations.



DET&Rinse™ PLUS
Art.: DB 1015



DET&Rinse™ ECO
Art.: DB 1018

The UNOX.Finest filter reduces or eliminates completely all the substances from the water which contribute to the formation of lime scale and/or rust inside the cooking chamber, a known cause of malfunctioning and breakdown. The control panel of your CHEFTOP MIND.Maps™ PLUS oven also monitors the quantity of water filtered by the UNOX.Finest system and automatically signals when it is time to replace the filter, optimising its use.



UNOX.Finest
Art.: XHC012

A range of excellence.

For safety and reliability purposes, CHEFTOP MIND.Maps™ Gas ovens (Free Standing and Countertop Models) must be equipped with only UNOX brand casters with safety chains, stacking kits, open stands neutral cabinets. Refer to UNOX Optional Accessories.

Certifications



18"x26" Full Sheet Pans



	XAVC-16FS-EPR	XAVC-10FS-EPR	XAVC-06FS-EPR
ELECTRIC			
Capacity	16 18"x26" or 32 12"x20" (Hotel Pans)	10 18"x26" or 20 12"x20" (Hotel Pans)	6 18"x26" or 12 12"x20" (Hotel Pans)
Pitch	3-5/16" (83,2 mm)	3-3/16" (80 mm)	3-3/16" (80 mm)
Frequency	60 Hz	60 Hz	60 Hz
Voltage	208 - 240 V 3-	208 - 240 V 3-	208 - 240 V 3-
Electrical power	35,9 - 47,8 kW	21,6 - 28,7 kW	14,3 - 19,1 kW
Maximum Amp Draw	118 A	71 A	47 A
Dimensions (WxDxH)	34 3/4" x 41 1/8" x 73 1/2" (882x1043x1866 mm)	33 7/8" x 37 11/16" x 45 13/16" (860x957x1163 mm)	33 7/8" x 37 11/16" x 33 1/4" (860x957x843 mm)
Weight	407 lbs (185 kg)	286 lbs (130 kg)	220 lbs (100 kg)
GAS			
Capacity	16 18"x26" or 32 12"x20" (Hotel Pans)	10 18"x26" or 20 12"x20" (Hotel Pans)	6 18"x26" or 12 12"x20" (Hotel Pans)
Pitch	3-5/16" (83,2 mm)	3-3/16" (80 mm)	3-3/16" (80 mm)
Frequency	60 Hz	60 Hz	60 Hz
Voltage	120 V 1-	120 V 1-	120 V 1-
Electrical power	1,6 kW	1 kW	0,8 kW
Maximum Amp Draw	20 A	19 A	12 A
Gas	G20, G25, G30, G31: 80 kW	G20, G25, G30, G31: 33 kW	G20, G25, G30, G31: 24 kW
Connected energy load:	273000 Btu/h	112600 Btu/h	82000 Btu/h
Dimensions (WxDxH)	34 3/4" x 41 1/8" x 73 1/2" (882x1043x1866 mm)	33 7/8" x 37 11/16" x 45 13/16" (860x957x1163 mm)	33 7/8" x 37 11/16" x 33 1/4" (860x957x843 mm)
Weight	462 lbs (210 kg)	319 lbs (145 kg)	242 lbs (110 kg)

Note: Door opening from left to right: Example of code XAVC-16FS-EPL (L= left) (R= right)

HIGH VOLTAGE ELECTRIC MODELS (440 - 480 V 3- / 18"x26" Full Sheet Pans):
XAVC-16FS-HPR (45,8 - 54,5 kW) / XAVC-10FS-HPR (27,5 - 32,7 kW) / XAVC-06FS-HPR (18,3 - 21,8 kW)

FEATURES

● Standard ○ Optional — Not available

ELECTRIC **GAS**

MANUAL COOKING MODES

Convection cooking 86 °F - 500 °F	●	●
Mixed steam and convection cooking 95 °F - 500 °F, with STEAM.Maxi™ 30% to 90%	●	●
Mixed humidity and convection cooking 95 °F - 500 °F, with STEAM.Maxi™ 10% to 20%	●	●
Steaming 95 °F - 266 °F with STEAM.Maxi™ technology 100%	●	●
Dry air cooking 86 °F - 500 °F with DRY.Maxi™ technology 10% to 100%	●	●
Delta T cooking with core probe	●	●
MULTI.Point core probe	●	●
SOUS-VIDE core probe	○	○

ADVANCED AND AUTOMATIC COOKING PROGRAMMING

MIND.Maps™ technology: draw cooking processes made of infinite steps with one simple touch	●	●
PROGRAMS: store up to 256 user's programs	●	●
PROGRAMS: possibility to assign a name and picture to the stored programs	●	●
PROGRAMS: save recipe name by writing it (in any language)	●	●
CHEFUNOX: select cooking mode (roast, braise, grill...), food to be cooked, food size and cooking result. and start cooking	●	●
MULTI.Time: technology to manage up to 10 timers to cook different products at the same time	●	●
MISE.EN.PLACE: technology to synchronize the food loading in the cooking chamber to have every pan ready at the same time	●	●

AIR DISTRIBUTION IN THE COOKING CHAMBER

AIR.Maxi™ technology: multiple, reversing fans	●	●
AIR.Maxi™ technology: 4 air speeds, programmable	●	●
AIR.Maxi™ technology: 4 semi static cooking modes, programmable	●	●

CLIMA MANAGEMENT IN THE COOKING CHAMBER

DRY.Maxi™ technology: high performance moisture and humidity extraction, programmable by the user	●	●
DRY.Maxi™ technology: cooking with humidity extraction 86 - 500 °F	●	●
STEAM.Maxi™ technology: steaming 95 °F - 266 °F	●	●
STEAM.Maxi™ technology: combination of moist air and dry air 95 °F - 500 °F	●	●
ADAPTIVE.Cooking™ technology: identifies cooking process optimization and automatically adjusts cooking parameters to grant perfect cooking results	●	●
ADAPTIVE.Cooking™ technology: one pan or full load, same result	●	●
ADAPTIVE.Cooking™ technology: humidity sensor and automatic adjustment	●	●

GN 1/1 (12"x20") Steam Table / Hotel Pans



	XAVC-1011-EPR	XAVC-0511-EPR	XACC-0513-EPR
Capacity	10 GN 1/1 - 12"x20" (Hotel Pans)	5 GN 1/1 - 12"x20" (Hotel Pans)	5 GN 1/1 - 12"x20" (Hotel Pans)
Pitch	2-5/8" (67 mm)	2-5/8" (67 mm)	2-5/8" (67 mm)
Frequency	60 Hz	60 Hz	60 Hz
Voltage	208 - 240 V 3-	208 - 240 V 3-	208 - 240 V 3-
Electrical power	11,6 - 15,5 kW	5,8 - 7,7 kW	5,8 - 7,7 kW
Maximum Amp Draw	38 A	19 A	19 A
Dimensions (WxDxH)	29 9/16" x 30 7/16" x 39 13/16" (750x773x1010 mm)	29 9/16" x 30 7/16" x 26 5/8" (750x773x675 mm)	21 1/8" x 33 15/16" x 25 9/16" (535x862x649 mm)
Weight	209 lbs (95 kg)	154 lbs (70 kg)	143 lbs (65 kg)
XAVC-1011-GPR		XAVC-0511-GPR	
Capacity	10 GN 1/1 - 12"x20" (Hotel Pans)	5 GN 1/1 - 12"x20" (Hotel Pans)	
Pitch	2-5/8" (67 mm)	2-5/8" (67 mm)	
Frequency	60 Hz	60 Hz	
Voltage	120 V 1-	120 V 1-	
Electrical power	0,8 kW	0,5 kW	
Maximum Amp Draw	8,5 A	5 A	
Gas	G20, G25, G30, G31: 22 kW	G20, G25, G30, G31: 15 kW	
Connected energy load:	75000 Btu/h	51000 Btu/h	
Dimensions (WxDxH)	29 9/16" x 30 7/16" x 39 13/16" (750x773x1010 mm)	29 9/16" x 30 7/16" x 26 5/8" (750x773x675 mm)	
Weight	242 lbs (110 kg)	187 lbs (85 kg)	

Door opening from left to right: Example of code XAVC-1011-EPL (L= left) (R= right)

Model 208 - 240 V 1- / 5 12"x20" Hotel Pans: XAVC-0511-MPR (4.1 - 5.5 kW)

ELECTRIC **GAS**

THERMAL INSULATION AND SAFETY

Protek.SAFE™ technology: maximum thermal efficiency and working safety (cool door glass and external surfaces)	●	●
Protek.SAFE™ technology: fan impeller break to contain energy loss at door opening	●	●
Protek.SAFE™ technology: electrical power absorption related to the real needs	●	—
Protek.SAFE™ technology: gas power absorption related to the real needs	—	●
Protek.SAFE™ PLUS: triple glazed door	●	●

HIGH PERFORMANCE PRESSURE BURNER

Spido.GAS™ technology: suitable for G20 / G25 / G25.1 / G30 / G31 gas types	—	●
Spido.GAS™ technology: high performance straight heat exchanger pipes for a symmetric heat distribution	—	●
Spido.GAS™ technology: straight heat exchanger pipes for an easy service	—	●

AUTOMATIC CLEANING

Rotor.KLEAN™: 4 automatic washing programs with detergent and water presence control	●	●
Rotor.KLEAN™: detergent tank integrated in the oven	●	●

PATENTED DOOR

Door hinges made of high durability and self-lubricating techno-polymer	●	●
Reversible door, even after the installation	○	○
Door docking positions at 60°-120°-180°	●	●

AUXILIARY FUNCTIONS

Preheating temperature up to 500 °F	●	●
Visualisation of the residual cooking time (when cooking not using the core probe)	●	●
Holding cooking mode «HOLD»	●	●
Continuous functioning «INF»	●	●
Visualisation of the set and real values of time, core probe temperature, cavity temperature, humidity, fan speed	●	●
Temperature unit in °C or °F	●	●

TECHNICAL DETAILS

Rounded stainless steel (AISI 304) cavity for hygiene and ease of cleaning	●	●
Chamber lighting through external LED lights	●	●
Steam proof sealed MASTER.Touch control panel	●	●
High-durability carbon fibre door lock	●	●
Door drip pan with continuous drainage, even when the door is open	●	●
High capacity appliance drip pan	●	●
Light weight - heavy duty structure using innovative materials	●	●
Proximity door contact switch	●	●
2-stage safety door lock	○	○
Autodiagnosis system for problems or brake down	●	●
Safety temperature switch	●	●
Openable internal glass to simplify door cleaning	●	●
Stainless steel C-shaped rack rails with notched recesses for easy loading	●	●

Ask for more.

HOODS



HOOD WITH STEAM CONDENSER FOR 18"X26" FULL SHEET PANS 16 TRAY ELECTRIC OVENS

Voltage: 208-240 V - 1N - Frequency: 60 Hz
Electrical power: 0.1 kW Exhaust chimney diameter: 4-3/4" (121 mm)
Min. air flow: 310 m3/h - Max. air flow: 390 m3/h
Dimensions (WxDxH): 34-3/16" x 45-5/8" x 9-7/16" (868x1159x240 mm) - Weight: 66 lbs (30 kg)
Art.: XAVHC-HCFL

HOOD WITH STEAM CONDENSER FOR 18"X26" FULL SHEET PAN ELECTRIC OVENS

Voltage: 208-240 V - 1N - Frequency: 60 Hz
Electrical power: 0.1 kW - Exhaust chimney diameter: 4-3/4" (121 mm)
Min. air flow: 310 m3/h - Max. air flow: 390 m3/h
Dimensions (WxDxH): 33-7/8" x 45-1/16" x 9-7/16" (860x1145x240 mm) - Weight: 55 lbs (25 kg)
Art.: XAVHC-HCFS

HOOD WITH STEAM CONDENSER FOR 12"X20" HOTEL PAN ELECTRIC OVENS

Voltage: 208-240 V - 1N - Frequency: 60 Hz
Electrical power: 0.1 kW - Exhaust chimney diameter: 4-3/4" (121 mm)
Min. air flow: 310 m3/h - Max. air flow: 390 m3/h
Dimensions (WxDxH): 29-1/2" x 37-5/8" x 9-7/16" (750x956x240 mm) - Weight: 55 lbs (25 kg)
Art.: XAVHC-HC11

HOOD WITH STEAM CONDENSER FOR 12"X20" (COMPACT GN 1/1) OVENS

Voltage: 208-240 V - 1N - Frequency: 60 Hz
Electrical power: 0.1 kW - Exhaust chimney diameter: 4-3/4" (121 mm)
Min. air flow: 310 m3/h - Max. air flow: 390 m3/h
Dimensions (WxDxH): 21 1/6" x 45/16" x 9-7/16" (535x1100x240 mm) - Weight: 44 lbs (20 kg)
Art.: XACHC-HC13

PROOFERS



PROOFER WITH INTEGRATED CONTROL FOR 18"X26" FULL SHEET PANS OVENS

Capacity: 12 18"x26" - Pitch: 3" (75 mm)
Voltage: 208-240 V - 1N
Frequency: 60 Hz - Electrical power: 2,4 kW
Max. temperature: 122 °F (50 °C)
Dimensions (WxDxH): 33-15/16" x 35-1/16" x 30" (862x890x762 mm)
Weight: 99 lbs (45 Kg)
Art.: XAVPC-12FS-C

WHEELS KIT WITH SAFETY CHAINS 4 WHEELS COMPLETE KIT:

2 wheels with brake - 2 wheels without brake.
Art.: XUC010

NEUTRAL CABINET



NEUTRAL CABINET FOR 18"X26" FULL SHEET PAN OVENS

Capacity: 8 18"x26" - Pitch: 2-1/4" (57 mm)
Dimensions (WxDxH): 33-7/8" x 35-1/2" x 24-5/16" (860x901x617 mm)
Weight: 55 lbs (25 Kg)
Art.: XWAEC-08EF

NEUTRAL CABINET FOR 12"X20" HOTEL PAN OVENS

Capacity: 8 GN 1/1 (12"x20")
Pitch: 2-1/4" (57 mm)
Dimensions (WxDxH): 29-9/16" x 25-7/8" x 26-5/8" (750x656x676 mm)
Weight: 40 lbs (18 kg)
Art.: XWVEC-0811

WHEELS KIT WITH SAFETY CHAINS 4 WHEELS COMPLETE KIT:

2 wheels with brake - 2 wheels without brake. Compatible with: XWVEC-0811/ XWARC-00EF-F
Art.: XUC010

QUICK.LOAD & QUICK.PLATE

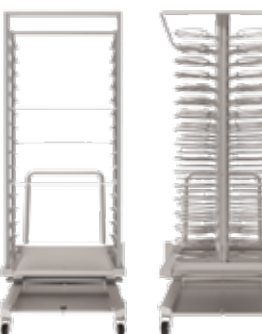

QUICK.LOAD FOR 20 18"X26" TROLLEY OVENS

Capacity: 16 18"x26"
Pitch: 3-5/16" (83,2 mm)
Dimensions (WxDxH): 29-5/8" x 25-3/4" x 66-1/8" (752x654x1679 mm)
Weight: 62 lbs (28 Kg)
Art.: XAVTC-16FS

QUICK.PLATE FOR 18"X26" FULL SHEET PAN TROLLEY OVENS

Capacity: 51 dishes
Max. dishes diameter: 12-1/4" (310 mm)
Min. dishes diameter: 8-5/16" (210 mm)
Dimensions (WxDxH): 29-5/16" x 22-1/4" x 67-3/8" (743x564x1711 mm)
Weight: 40 Kg
Art.: XEVTC-051P

SMART.DRAIN



SMART.DRAIN (COOKING FAT AND LIQUID COLLECTION SYSTEM)

SMART.DRAIN manual kit for neutral cabinet and high open stand
Compatible with XWAEC-08EF/XWVEC-0811/XWARC-00EF-H/XWVRC-0011-H
Art.: XUC020

See UNOX SMART.DRAIN suggested solutions (OPEN, CLOSED) page 29

STANDS



HIGH OPEN STAND FOR 18"X26" FULL SHEET PAN OVENS

Dimensions (WxDxH): 33-3/16" x 28-1/8" x 29-5/8" (842x713x752 mm)
Weight: 24 lbs (11 Kg)
Art.: XWARC-00EF-H

LATERAL SUPPORT FOR STAND FOR 18"X26" FULL SHEET PANS OVENS

For model: XWARC-00EF-H
Capacity: 7 18"x26"
Pitch: 2-3/8" (60 mm)
Weight: 7 lbs (3 Kg)
Art.: XWALC-07EF-H

INTERMEDIATE OPEN STAND FOR 18"X26" FULL SHEET PAN OVENS

Dimensions (WxDxH): 33-3/16" x 28-1/8" x 18-1/4" (842x713x462 mm)
Weight: 20 lbs (9 Kg)
Art.: XWARC-00EF-M

LOW OPEN STAND FOR 18"X26" FULL SHEET PAN OVENS

Dimensions (WxDxH): 33-3/16" x 28-1/8" x 12-1/16" (842x713x305 mm)
Art.: XWARC-00EF-L

FLOOR STAND FOR 18"X26" FULL SHEET PAN OVENS

Dimensions (WxDxH): 33-3/16" x 28-1/8" x 6-1/2" (842x713x163 mm)
Art.: XWARC-00EF-L

HIGH OPEN STAND FOR 12"X20" HOTEL PAN OVENS

Dimensions WxDxH): 28-7/8" x 21-1/2" x 29-5/8" (732x546x752 mm)
Weight: 22 lbs (10 Kg)
Art.: XWVRC-0011-H

LATERAL SUPPORT FOR STAND FOR 12"X20" HOTEL PAN OVENS

For model: XWVRC-0011-H
Capacity: 7 GN 1/1 (12"x20")
Pitch: 2-3/8" (60 mm)
Weight: 5 lbs (2 Kg)
Art.: XWVLC-0711-H

INTERMEDIATE OPEN STAND FOR 12"X20" HOTEL PAN OVENS

Dimensions WxDxH): 28-7/8" x 21-1/2" x 18-1/4" (732x546x462 mm)
Weight: 20 lbs (9 Kg)
Art.: XWVRC-0011-M

FLOOR STAND FOR 12"X20" HOTEL PAN OVENS

Dimensions WxDxH): 28-7/8" x 21-1/2" x 4-1/2" (732x546x113 mm)
Art.: XWVRC-0011-F

HIGH OPEN STAND FOR 12"X20" (COMPACT GN 1/1) HOTEL PAN OVENS

For models: XACC-0513-EPR
Dimensions (WxDxH): 21 x 4-3/8" x 9-1/2" (518x684x673 mm) Weight: 22 lbs (10 kg)
Art.: XWCRC-0013-H

LATERAL SUPPORT FOR STAND FOR 12"X20" (COMPACT GN 1/1) HOTEL PAN OVENS

For model: XWCRC-0013-H
Capacity: 6 GN 1/1
Pitch: 2 3/8" (60 mm)
Weight: 4.4 lbs (2 kg)
Art.: XWCLC-0613-H

LOW OPEN STAND FOR 12"X20" (COMPACT GN 1/1) HOTEL PAN OVENS

For models: XACC-0513-EPR
Dimensions (WxDxH): 21 x 4-3/8" x 12-1/16" (518x684x305 mm)
Weight: 13.2 lbs (6 kg)
Art.: XWCRC-0013-L

WHEELS KIT WITH SAFETY CHAINS 4 WHEELS COMPLETE KIT:

2 wheels with brake - 2 wheels without brake. Compatible with: XWVRC-0011-F/ XWVRC-0011-M/ XWVRC-0011-H/ XWARC-00EF-F/ XWARC-00EF-L/ XWARC-00EF-M/ XWARC-00EF-H
Art.: XUC010

UNOX.CARE



DET&Rinse™ ECO

ECO friendly double concentrate detergent & rinsing agent.
10 lt of DET&Rinse™ ECO = 18 lt of traditional oven detergent.
One box contains n° 10 x 1 litre tanks.
Art.: DB1018

DET&Rinse™ PLUS

Double concentrate
10 lt of DET&Rinse™ PLUS = 18 lt of traditional oven detergent
One box contains n° 10 x 1 litre tanks.
Art.: DB1015

UNOX.FINEST

Art.: XHC012

HYPER.SMOKER



FOR CHEFTOP MIND.Maps™ PLUS OVENS

The XUC090 is compatible only with CHEFTOP MIND.Maps™ PLUS ovens set up for its usage.
The compatibility of the HYPER.Smoker is guaranteed for all electric ovens produced starting from 15th June 2016 and for all gas produced starting from 5th August 2016. It is necessary to check the compatibility with models which have been produced earlier.
Art.: XUC090

INTERNET CONNECTION



OPTIONALS FOR INTERNET CONNECTION FOR CHEFTOP MIND.Maps™ PLUS OVENS

WiFi connection kit

Art.: XEC006

Illustrative photo refers to XEC006 kit

Like having an extra member of the brigade

LONGLife4

Spare parts 4 years / 10.000 hours optional warranty*

FORO.BLACK



AVAILABLE IN SIZES:

> 12"x20" Art.: TG 890
> 18"x26" Art.: TG 520

GRILL

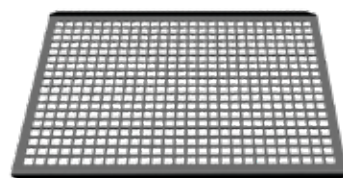

AVAILABLE IN SIZES:

> 18"x26" Art.: TG885
> 12"x20" Art.: TG530

FORO.BAKE



AVAILABLE IN SIZES:

• 18"x26" Art.: TG 410

FORO.BAGUETTE



AVAILABLE IN SIZES:

• 18"x26" Art.: TG 445

POLLO.BLACK

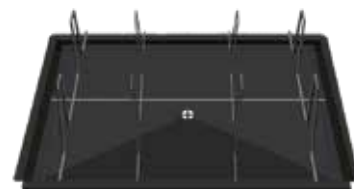

AVAILABLE IN SIZES:

> 12"x20" Art.: GRP 825 (capacity 8 chickens)
> 18"x26" Art.: GRP 570 (capacity 10 chickens)

PAN.FRY

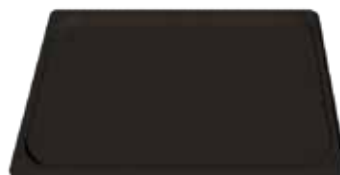

AVAILABLE IN SIZES:

> 12"x20" Art.: TG. 905
> 18"x26" Art.: TG 525

CHROMO.GRID

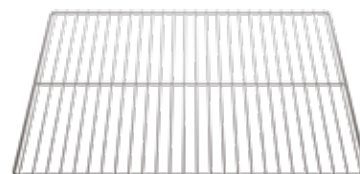

AVAILABLE IN SIZES:

> 12"x20" Art.: GRP 806
> 18"x26" Art.: GRP 560

STEAM&FRY



AVAILABLE IN SIZES:

> 12"x20" Art.: GRP 815
> 18"x26" Art.: GRP 575

BACON

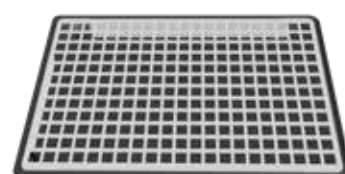

AVAILABLE IN SIZES:

> 12"x20" Art.: TG 945

EGGX



AVAILABLE IN SIZES:

> 12"x20" Art.: TG 935

BLACK.20



AVAILABLE IN SIZES:

> 12"x20" Art.: TG 895

UNOX LONGLife4 EXTENDED WARRANTY & CERTIFIED INSTALLATION PROGRAM
UNOX LongLife4, extended warranty with certified installation. UNOX LongLife4 program includes the following, which remains subject to UNOX, INC Terms and conditions: Extended Warranty providing a 4yr/10,000 ON hours parts/1 yr labor warranty. Oven must be connected to the internet via Ethernet cable, or WIFI and must remain accessible for remote login by UNOX service team. Pre-installation site inspection by an UNOX Certified Service Agent, of the site where the UNOX equipment will be installed, and follow-up instructions advising customer of any additional material needed for site preparation required prior to installation of the UNOX equipment. Assembly, setting and leveling of the UNOX equipment & Final Hook-up by Certified UNOX Service Agent. Any additional costs for the installation beyond those provided as part of the UNOX LONGLife4 Extended Warranty & Certified Installation Program, is the responsibility of the customer. UNOX LONGLife Certified Installation Program includes the following, which remains subject to UNOX, INC.s Terms and Conditions:

1. a pre-installation survey of the site where the UNOX equipment will be installed, and follow-up instructions advising customer or its client of site preparation required prior to installation of the UNOX equipment;
2. travel by UNOX, INC. or its designee, within a fifty (50) mile radius (one hundred (100) miles round trip) of UNOX, INC. or its designee's office;
3. assembly, setting and leveling of the UNOX equipment;
4. start-up demonstration;
5. 4-year warranty on parts and 1-year warranty on labor commencing on the earlier of (1) three (3) months after delivery of the UNOX equipment to customer, and (2) installation of UNOX equipment on customer's or customer's client's site, as applicable, as set forth in the UNOX, INC. Terms and Conditions.

Oven must be connected to the internet via Ethernet cable or WIFI and must remain accessible for remote login by UNOX service team.

An UNOX service agent will perform a pre-installation site survey of the location where the UNOX equipment is to be installed. Upon completion of the site survey, the UNOX service agent will advise the customer of all the required site preparations required, prior to any installation being performed.

On the scheduled day of installation, the customer must ensure that the UNOX equipment is

properly positioned within three feet of the installation location and that the work area (within six feet of the equipment) is free and accessible for the UNOX service agent to work.

Installation of the UNOX equipment beyond fifty (50) mile radius (one hundred (100) miles round trip) of UNOX, INC. or its designee's office will require an additional travel charge. If the installation of the UNOX equipment cannot be completed due to local codes and/or government authorities, or if there is a disruption in electrical or water service at the time of installation, or if the UNOX Service agent is unable to access the utilities due to activities at the facility beyond his/her control, the UNOX Service agent will, upon request, provide supervision of the final installation at a later date to be determined by UNOX, INC.

The use of any additional contractor labor, travel and/or parts other than those specified in the UNOX LONGLife4 Extended Warranty & Certified Installation Program, is the responsibility of the customer.

The UNOX LONGLife4 Extended Warranty & Certified Installation Program does not include the following:

1. overtime travel or labor;
2. travel by UNOX service agent or its designee, beyond a fifty (50) mile radius (one hundred (100) miles round trip) of UNOX, INC. or its designee's office;
3. any work or costs associated with moving the equipment within 3 feet of the final installed location
4. special licensing or permits;
5. unpacking, uncrating and removal of packing material of UNOX equipment;
6. removal and scrapping of old equipment

*It is highly recommended that UNOX Pure cleaning filtration system (head and filter kit) be incorporated into all UNOX combi oven installations, to prevent scale buildup and to extend the life of the UNOX oven. It is the sole responsibility of the owner/operator/purchaser of the UNOX equipment to verify that the incoming water supply is comprehensively tested & if required, provide a means of water treatment that would meet the minimum requirements with UNOX water quality standards as outlined on the product spec sheet. Non-compliance with these minimum standards will potentially damage this equipment and/or components & VOID the original equipment manufacturers warranty and LONGLife4.

OPTIONALS FOR INTERNET CONNECTION FOR CHEFTOP MIND.MAPS™ PLUS OVENS

Art.: XEC006

WiFi connection kit





UNOX INC.
 987 Airlie Parkway
 Denver, NC 28037
 1-800-489-UNOX
infousa@unox.com



INVENTIVE SIMPLIFICATION

EUROPE

ITALIA
UNOX S.p.A.
 E-mail: info@unox.it
 Tel.: +39 049 86 57 511

ČESKÁ REPUBLIKA
UNOX DISTRIBUTION s.r.o.
 E-mail: info.cz@unox.com
 Tel.: +420 241 940 000

РОССИЯ, ПРИБАЛТИКА И СТРАНЫ СНГ
UNOX РОССИЯ
 E-mail: info.ru@unox.com
 Tel.: +7 (499) 702-00-14

ESPAÑA
UNOX PROFESIONAL ESPAÑA S.L.
 E-mail: info.es@unox.com
 Tel.: +34 900 82 89 43

SCANDINAVIAN COUNTRIES
UNOX SCANDINAVIA AB
 E-mail: info.se@unox.com
 Tel.: +46 (0)768 716 422

UNITED KINGDOM
UNOX UK Ltd.
 E-mail: info@unoxuk.com
 Tel.: +44 1252 851 522

PORTUGAL
UNOX PORTUGAL
 E-mail: info.pt@unox.com
 Tel.: +351 918 228 787

DEUTSCHLAND
UNOX DEUTSCHLAND GmbH
 E-mail: info.de@unox.com
 Tel.: +49 2951 98760

FRANCE, BELGIUM & LUXEMBOURG
UNOX FRANCE s.a.s.
 E-mail: info@unox.fr
 Tel.: +33 4 78 17 35 39

ÖSTERREICH
UNOX ÖSTERREICH GmbH
 E-mail: bestellung@unox.com
 Tel.: +43 800 880 963

HRVATSKA
UNOX CROATIA
 E-mail: narudzbe@unox.com
 Tel.: +39 049 86 57 538

TÜRKİYE
UNOX TURKEY Profesyonel Mutfak
 Ekipmanları Endüstri ve Ticaret Limited Şirketi
 E-mail: info.tr@unox.com
 Tel.: +90 530 176 62 03

IRELAND
UNOX IRELAND
 E-mail: info.ie@unox.com
 Tel.: +353 (0) 87 32 23 218

БЪЛГАРИЯ
UNOX BULGARIA
 E-mail: info.bg@unox.com
 Tel.: +359 88 23 13 378

ASIA & AFRICA

MALAYSIA & SINGAPORE
UNOX (ASIA) SDN. BHD
 E-mail: info.asia@unox.com
 Tel.: +603-58797700

OTHER ASIAN COUNTRIES
UNOX (ASIA) SDN. BHD
 E-mail: info.asia@unox.com
 Tel.: +603-58797700

PHILIPPINES
UNOX PHILIPPINES
 E-mail: info.asia@unox.com
 Tel.: +63 9173108084

대한민국
UNOX KOREA CO. Ltd.
 이메일: info.asia@unox.com
 전화: +82 2 69410351

AMERICA & OCEANIA

U.S.A. & CANADA
UNOX Inc.
 E-mail: infousa@unox.com
 Tel.: +1 800 489 8669

MEXICO
UNOX MEXICO, S. DE R.L. DE C.V.
 E-mail: info.mx@unox.com
 Tel.: +52 1555 4314 180

BRAZIL
UNOX BRAZIL
 E-mail: info.br@unox.com
 Tel.: +55 11 98717-8201

U.A.E.
UNOX MIDDLE EAST DMCC
 E-mail: info.uae@unox.com
 Tel.: +971 55 426 3167

SOUTH AFRICA
UNOX SOUTH AFRICA
 E-mail: info.sa@unox.com
 Tel.: +27 845 05 52 35

INDONESIA
UNOX INDONESIA
 E-mail: info.asia@unox.com
 Tel.: +62 81908852999

中华人民共和国
UNOX TRADING (SHANGHAI) CO. Ltd.
 电子邮件: info.china@unox.com
 电话: +86 21 56907696

COLOMBIA
UNOX COLOMBIA
 E-mail: info.co@unox.com
 Tel.: +57 350 65 88 204

AUSTRALIA
UNOX AUSTRALIA PTY Ltd.
 E-mail: info@unoxaustralia.com.au
 Tel.: +61 3 9876 0803

NEW ZEALAND
UNOX NEW ZEALAND Ltd.
 E-mail: info@unox.co.nz
 Tel.: +64 (0) 800 76 0803

UNOX.COM | FOLLOW US ON

